

# Model 6281D WIERTARKO-WKRĘTARKA BEZPRZEW

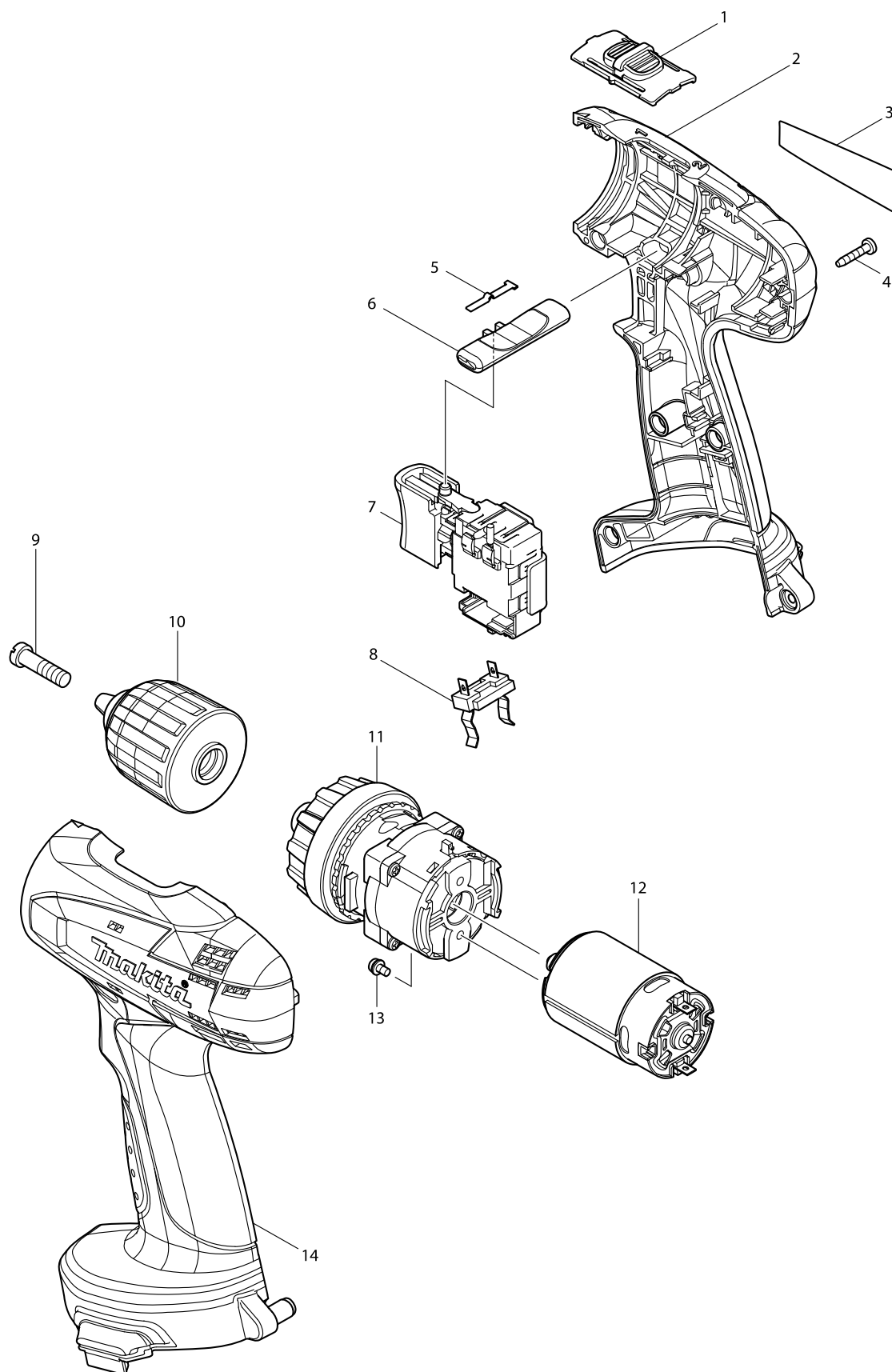

# Model 6281D WIERTARKO-WKRĘTARKA BEZPRZEW

Artykuł	Nr katalogowy	Opis	Zam.	Ilość	N/O	Sprzedaż	Zakup	Uwaga
001	125310-5	PRZEŁĄCZNIK ZMIANY BIEGÓW do BL		1		2,20		
C10	231433-0	SPRĘŻYNA		2		0,60		
002	188512-4	(zam.187301-4 TI.93269) OBUDOWA KF		1	*	28,80		
D10		INC. 14			*			
002-1	187301-4	OBUDOWA KPL. do 6281/8281DWAE	<	1		25,00		
D10		INC. 14						
003	865168-7	TABLICZKA ZNAMIONOWA do 6281D		1		0,60		
004	266130-9	(AM) ŚRUBA 3X16 6213DWA		9		0,60		
005	232182-2	SPRĘŻYNA PŁASKA		1		1,70		
006	450584-2	DŹWIGNIA ZMIANY KIERUNKU OBROT		1		1,20		
007	650601-0	(zam.650663-8 TI.91796) WŁĄCZNIK TC		1	*	33,00		
007-1	650601-0	(zam.650663-8 TI.91796) WŁĄCZNIK TC	O	1	*	33,00		
007-2	650663-8	(zam.650672-7 TI.93884) WŁĄCZNIK TC	<	1	*	33,00		
007-3	650672-7	WŁĄCZNIK TG563FSB-2 do 6271/81DW	<	1		33,00		
008	643909-9	NOWY 417106 STYK 4300/4071/UH300		1		10,80		
009	251468-5	ŚRUBA M6x22		1		0,60		
010	766002-3	(zam. 196309-7) SAMOZACISKOWY UC		1		22,15		
011	125482-6	(zam.126000-3(BDF343)(TI.93295) PRZ		1		66,00		
012	629819-4	(zam.629875-4(6281D) / 629898-2(BDF3		1	*	25,00		
012-1	629875-4	SILNIK DC do 6281D	O	1		16,80		
013	911003-8	ŚRUBA M3x6		2		0,60		
014	188512-4	(zam.187301-4 TI.93269) OBUDOWA KF		1	*	28,80		
D10		INC. 2			*			
014-1	187301-4	OBUDOWA KPL. do 6281/8281DWAE	<	1		25,00		
D10		INC. 2						
A01	***DC1414	DC1414 BATTERY CHARGER		1				
A02A	192600-1	1422 AKUMULATOR 14.4V;1.9Ah		2		219,52		
A02B	192600-1	1422 AKUMULATOR 14.4V;1.9Ah		2		219,52		
A02C	193985-8	AKUMULATOR PA14 Ni-Cd 14,4V 1,3Ah		2		122,40		
A03	414938-7	OSŁONA STYKÓW AKUMULATORA		2		0,56		
A04	784636-0	KOŃCÓWKA DO WKRĘCANIA 65mm 1,		1		4,48		
A05A	824852-3	WALIZKA TRANSPORTOWA do 8281D		1		39,20		
A05B	824853-1	WALIZKA TRANSPORTOWA do 6261-8		1		44,94		
A05C	824852-3	WALIZKA TRANSPORTOWA do 8281D		1		39,20		
A06B	345261-8	PŁYTKA HACZYKA do ML		2		13,60		
A07B	417926-3	PASEK do ML		1		15,20		
A08B	192752-8	LATARKA 14,4V ML140		1		91,00		
D10		INC. A06,A07						
E02	688165-4	FILTR LINIOWY do BUB360		1		1,20		
E03	688164-6	(AM) FILTR LINIOWY do CL102D		1		0,60		